



SENCE

furu6



furu9

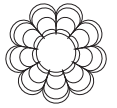

muna



mogen6



mogen9

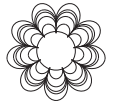

skog



blom



„Les je lep naraven material.
Omogoča nam oblikovanje
senčil, ki prepuščajo
svetlobo polno topline in
mehkobe.
S prijetno svetlobo je
življenje lepše.“

„Wood is a beautiful
natural material.
We use it to produce shades
that give a pleasant warm
touch to the light they
diffuse.
Pleasant light makes life
enjoyable.“

arne vehovar, SENCE



SENCE

oblikovano / designed circa 1962

Družina svetil SENCE je nadaljevanje znamenite linije luči, ki jo je na začetku šestdesetih let dvajsetega stoletja zasnoval mlad par arhitektov. Ona hči kiparja, on sin mizarja, oba pod močnim vplivom skandinavskega oblikovanja. Kmalu po končanem študiju sta Nives in Franci Vehovar oblikovala ikonično družino svetil iz lesenega furnirja.

Luči so v strokovni javnosti vzbudile veliko zanimanja. Leta 1964 so bile nagrajene z nagrado Prešernovega sklada in častno pohvalo prvega Bienala industrijskega oblikovanja v Ljubljani.

Vsi modeli so bili v celoti ročno izdelani in se nikoli niso serijsko proizvajali.

Pol stoletja pozneje je s pomočjo nove tehnologije na voljo osvežena in zahtevam sodobne uporabe prilagojena izvirna kolekcija, razširjena z novimi oblikami.

Senčniki so narejeni iz skrbno izbranih, tehnološko obdelanih naravnih lesenih furnirjev. Lasersko izrezani kosi so ročno sestavljeni v prepoznavno končno obliko.

This calming set of lights descends from a famous lineage of lights that were designed at the beginning of the 1960s by two young architects. She was a daughter of a sculptor, he a son of a carpenter, both were evidently influenced by Scandinavian design. Soon after the completion of their studies Nives and Franci Vehovar created an iconic family of lights made from wood veneer.

The lamps were soon recognized by the professional public and in 1964 they were awarded with the national award for the achievements in culture, and a honorary mention at the first Biennial of industrial design - BIO in Ljubljana.

The lamps were made entirely by hand, and were never mass produced.

Half a century later, with the help of new technologies, the original collection is offered redesigned, with new shapes and addressing contemporary uses.

This signature shades are made from carefully selected, technologically processed natural veneers. Laser cut components are manually assembled into the final form.

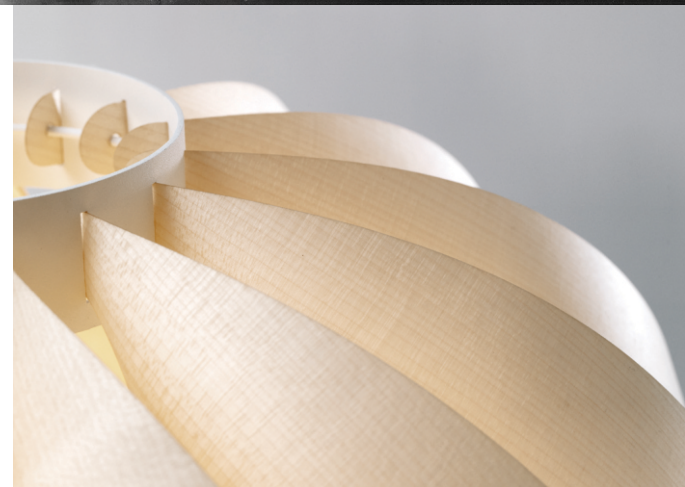



furu6

Available as a pendant and floor lamp.
Medium and Large.

Na voljo kot viseča in talna luč.
Velika in srednje velika.

oblikovanje / design:
Nives Kalin Vehovar in Franci Vehovar, circa 1962

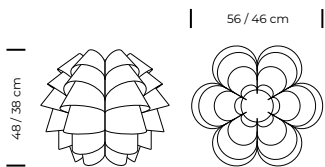

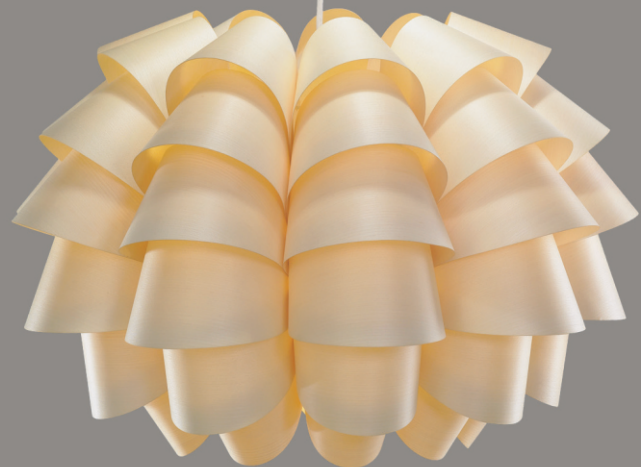

furu9

Available as a pendant, table and floor lamp.
Small, medium and large.

Na voljo kot viseča, namizna in talna luč.
Velika, srednje velika in majhna.

preoblikovanje / re-design:
Kaja Lipnik Vehovar in Arne Vehovar, 2015

| 48 / 38 / 27 cm |

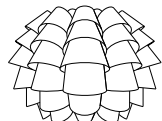

| 72 / 56 / 38 cm |

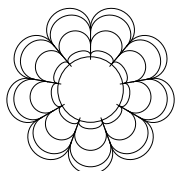



muna

Available as a pendant, table and floor lamp.
Small and medium.

Na voljo kot viseča, namizna in talna luč.
Srednje velika in majhna.

oblikovanje / design:
Nives Kalin Vehovar in Franci Vehovar, circa 1962

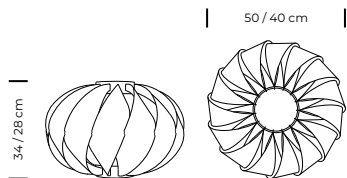

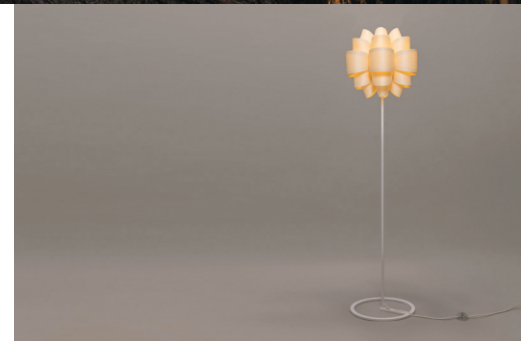
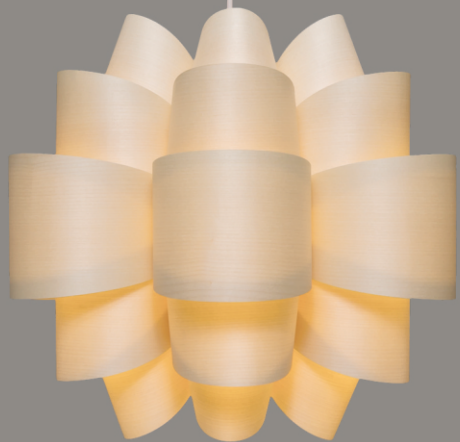

mogen6

Available as a pendant and floor lamp.
Medium and Large.

Na voljo kot viseča in talna luč.
Velika in srednje velika.

oblikovanje / design:
Kaja Lipnik in Arne Vehovar, 2015

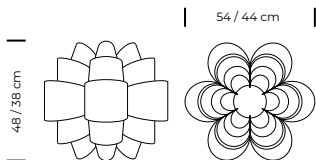



mogén9

Available as a pendant, table and floor lamp.
Small, medium and Large.

Na voljo kot viseča, namizna in talna luč.
Velika, srednje velika in majhna.

oblikovanje / design:
Kaja Lipnik Vehovar in Arne Vehovar, 2015

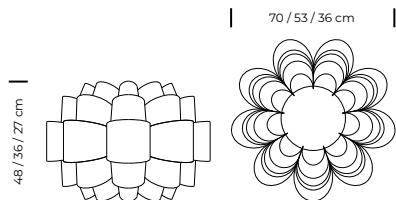



skog

Available as a pendant, table and floor lamp.
Small and medium.

Na voljo kot viseča, namizna in talna luč.
Srednje velika in majhna.

oblikovanje / design:
Nives Kalin Vehovar in Franci Vehovar, circa 1962

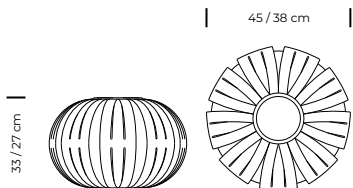

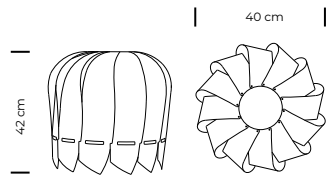

Available as a pendant lamp.
Medium.

blom

Na voljo kot viseča luč.
Srednje velika.

oblikovanje / design:
Nives Kalin Vehovar in Franci Vehovar, circa 1962

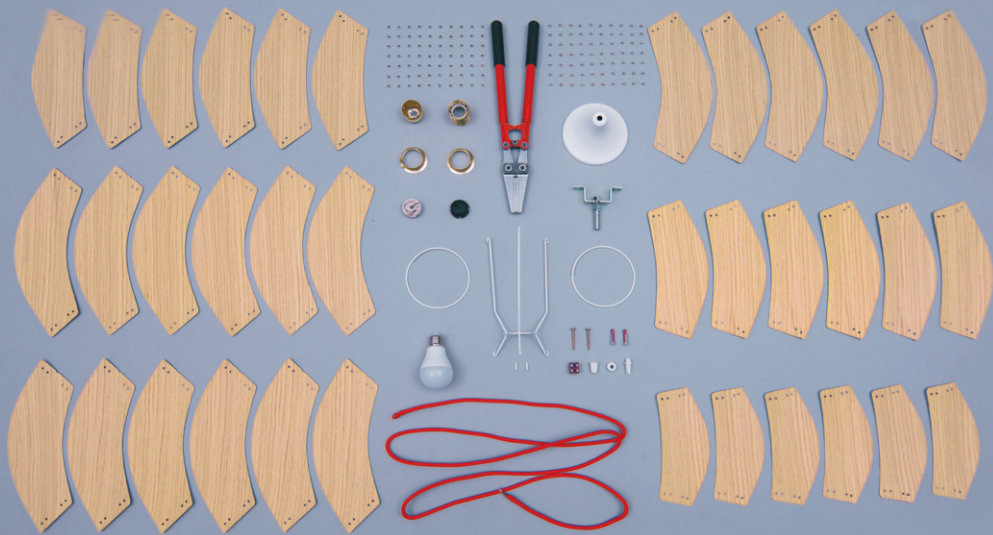

javor / maple

smreka / spruce

macesen / larch

hrast / oak

oreh / walnut

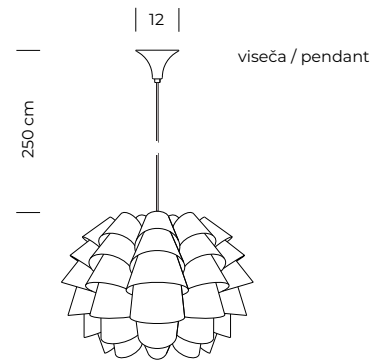
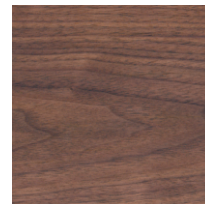
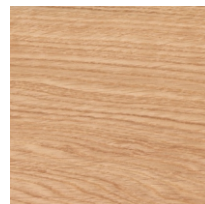

Vsi furnirji, ki jih uporabljamo za izdelavo naših luči, so iz trajnostno pridobljenega lesa. Furnirji so brušeni na debelino 0,35-0,55mm, kaširani s flisom ki preprečuje pukanje in obojestransko lakirani z okolju prijaznimi laki. Sestavni deli so lasersko izrezani in ročno spojeni v končno obliko.

Vsi kovinski deli so prašno barvani s finostrukturnimi barvami. Stropne rozete in podnožja namiznih in talnih luči so na voljo v beli in črni barvi.

Za viseče luči je mogoče izbirati med tekstilnimi kablji v različnih barvah. Vsaki luči je priložena ustrezna LED sijalka z barvo svetlobe 2700 / 3000K ter E27 navojem.

Za embalažo ne uporabljamo plastičnih materialov. Vso embalažo je mogoče v celoti reciklirati.

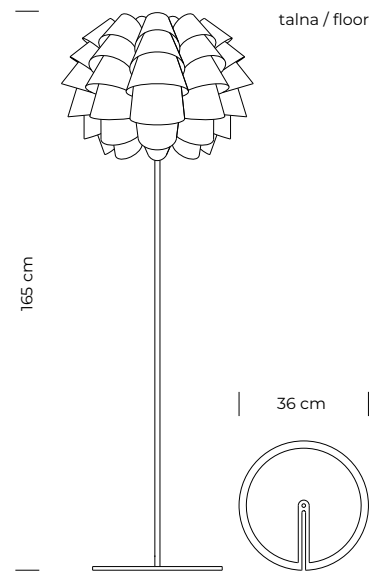

All the veneers that we use for production of our lights are cut from sustainably obtained wood.

Veneers are sanded to a thickness of 0.35-0.55mm, laminated with a fleece that prevents cracking and are lacquered on both sides with environmentally friendly lacquers. The components are laser-cut and manually assembled into the final form.

All metal parts are powder coated with fine structured matt finish. Ceiling cups and bases of table and floor lamps are available in white and black.

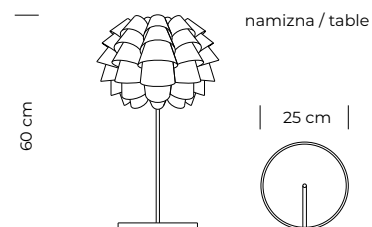

For pendants, it is possible to choose between textile cables in various colours. Each lamp is supplied with an appropriate LED light bulb, with a warm colour of light (2700 / 3000K) and E27 thread.

We do not use plastic materials for packaging. All packaging can be fully recycled.



SENCE

kubus interier d.o.o., rimska 23, 1000 ljubljana, slovenija
sence@kubus-interier.si
www.sence-luci.si

